

EXU-SF/ECU-SF Technical Data

Low Lift Pallet Truck with Hinged Platform

EXU-SF 20/Li-Ion

ECU-SF 20



EXU-SF Low Lift Pallet Truck with Hinged Platform

Precision and manoeuvrability

This specification sheet to VDI Guidelines 2198 only provides technical values for the standard truck. Different tyres, other masts, additional equipment etc. may produce different figures.



Distinguishing marks				STILL	
1.1	Manufacturer			STILL	
1.2	Manufacturer's type designation			EXU-SF 20/Li-Ion	
1.3	Drive			Electric	
1.4	Operator type			Standing/pedestrian	
1.5	Capacity/load	Q	kg	2000	
1.6	Load centre distance	c	mm	600	
1.8	Load distance	x	mm	1023 ²	
1.9	Wheel base	y	mm	1518 ²	1589 ²
Weights				kg	
2.1	Service weight (incl. battery)			754	866
2.2	Axle load, laden	drive end/load end		kg	1090/1664 1242/1624
2.3	Axle load, unladen	drive end/load end		kg	590/164 678/188
Tyres/chassis					
3.1	Tyres			Polyurethane	
3.2	Tyre size	drive end		mm	∅ 230 x 75
3.3	Tyre size	load end		mm	2 x ∅ 85 x 80
3.4	Support castors	drive end		mm	∅ 140 x 54 (∅ 110 x 60) ¹
3.5	Number of wheels (x = driven)	drive end/load end		1 x -2/4	
3.6	Tread	drive end/load end	b ₁₀ /b ₁₁	mm	495/388
Dimensions					
4.4	Lift		h ₃	mm	130
4.8	Seat height/standing height (platform)		h ₇	mm	198
4.9	Height of tiller in driving position	min./max.	h ₁₄	mm	1120/1370
4.15	Height lowered		h ₁₃	mm	85
4.19	Overall length without load	platform closed/open	l ₁	mm	1925/2333 2001/2409
4.20	Length to face of forks	platform closed/open	l ₂	mm	735/1143 811/1219
4.21	Total width		b ₁	mm	720
4.22	Fork dimensions		s/e/l	mm	55/172/1190
4.25	Overall fork width		b ₅	mm	560
4.32	Ground clearance, centre of wheel base		m ₂	mm	30
4.34	Working aisle width with 800 x 1200 pallet lengthways (b ₁₂ x l ₆)	platform closed/open	A _{st}	mm	2134/2746 ³ 2210/2822 ³
4.35	Turning radius	platform closed/open	W _a	mm	1752 ² /2165 ² 1833 ² /2241 ²
Performance					
5.1	Travel speed	laden/unladen		km/h	7.5/9.0 (8.5/10 ¹)
5.2	Lift speed	laden/unladen		m/s	0.093/0.093
5.3	Lowering speed	laden/unladen		m/s	0.14/0.11
5.7	Gradeability	laden/unladen		%	10/20
5.9	Acceleration time (over 10 m)	laden/unladen		s	6.9/5.4 6.9/5.5
5.10	Service brake				Electromagnetic
Electric engine					
6.1	Drive motor, rating S2 = 60 min			kW	2.3
6.2	Lift motor, rating at S3			kW	2.2/8%
6.3	Battery according to DIN 43531/35/36; A, B, C, no				2PzS 3PzS
6.4	Battery voltage/nominal capacity K ₅			V/Ah	24/250 Li-Ion: 24/82 24/375
6.5	Battery weight ±5% (depends on make)			kg	212 288
6.6	Energy consumption according to VDI cycle			kWh/h	0.52 0.75
Other					
8.1	Drive control				AC control
8.4	Sound level at driver's ear			dB(A)	66

¹ with STILL DRIVESpeed

² initial lift lowered; initial lift raised = -133mm

³ initial lift raised

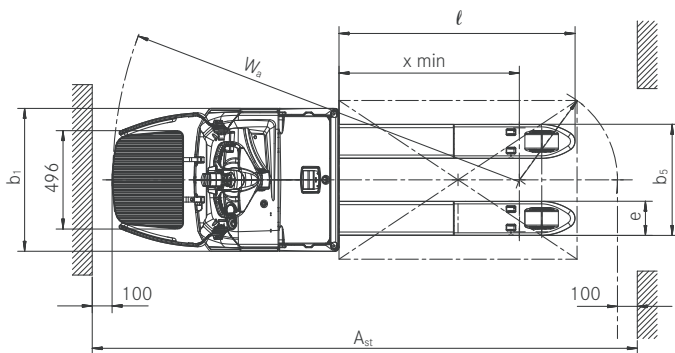

Top view

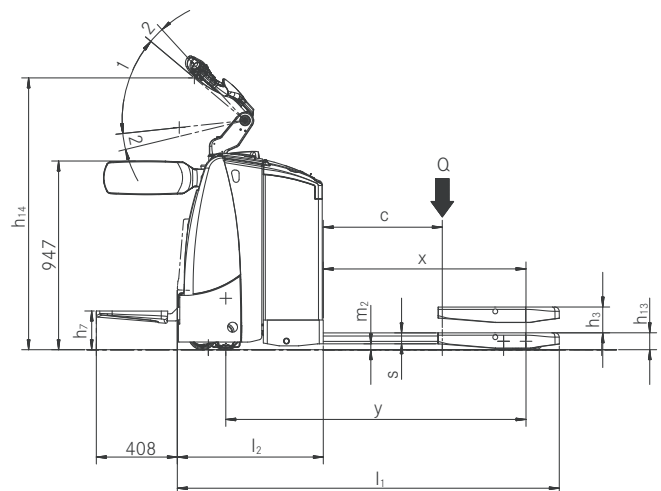

Side view

EXU-SF Low Lift Pallet Truck with Hinged Platform Turning Radius

Turning radius W_a and load distance x with lowered initial lift

Fork length ℓ		Distance x	Unfolded Platform	Folded Platform	Distance x	Unfolded Platform	Folded Platform
990	mm	823	250 Ah	250 Ah	823	350 Ah	350 Ah
990	mm	805	-	-	805	2023	1615
1190	mm	1023	2165	1752	1023	2241	1833
1190	mm	1005	-	-	1005	2223	1815
1600	mm	1433	2575	2162	1433	2651	2243
1600	mm	1415	-	-	1415	2633	2225
¹ 2390	mm	-	-	-	2205	3423	3015
² 2390	mm	-	-	-	1847	3065	2657

¹ Wheel base suitable for lifting three Euro pallets crossways

² Wheel base suitable for lifting two Euro pallets lengthways

Detailed Photos



The optional combi-tiller increases the safety distance to the operator, ensuring even greater safety during operation



All-round safety: height-adjustable side guards keep the driver safe and stable, and provide optimal protection in all driving situations



Battery changing made easy: optional lateral battery change for even greater availability and improved ergonomics



Protects the back: the air-cushioned stand-on platform can be adjusted to individual driver's weight



Maximum driver protection: sensitive impact plate in the optimal position plus height-adjustable foot guard

EXU-SF Low Lift Pallet Truck with Hinged Platform

Precision and manoeuvrability

Protects the back: the air-cushioned stand-on platform can be adjusted to individual driver's weight

Maximum safety distance: the optional combi-tiller increases the safety distance to the operator, ensuring even greater safety during operation

All-round safety: height-adjustable side guards keep the driver safe and stable, and provide optimal protection in all driving situations



The powerful EXU-SF low lift pallet truck from STILL with a hinged platform and a load capacity of up to 2,000 kg is designed for work in very narrow spaces and for transporting goods horizontally. This compact warehouse helper can be manoeuvred accurately and safely in narrow spaces. All of which makes it the ideal choice for loading and unloading lorries. The truck enables goods to be turned around fast over multiple shifts in the industrial sector and rapid material handling in retail environments. The unique STILL combi-tiller can be folded down to increase speed in pedestrian mode.

This means that material can be transported fast with the highest levels of safety. The air suspension on the stand-on platform, which can be individually adjusted to the driver's weight, and the height-adjustable side guards provide a high level of comfort and safety. The precise and intuitive electrical steering unit minimizes operator fatigue. The performance of the EXU-SF can be adapted to the job at hand at the touch of a button: The ECO and BOOST driver programmes allow drivers to choose between maximum performance and maximum efficiency.

Extensive Equipment

Power

- Powerful, reliable and low-maintenance AC drive motor
- The right driving programme for all situations: Select maximum turnaround or maximum efficiency: ECO or BOOST
- Enough power for multiple shifts: high battery capacity and optional lateral battery changing
- Extreme availability: the lithium-ion battery possesses incredible energy and allows for quick and easy interim charging
- Outstanding reliability: reinforced fork tips for demanding jobs on ramps

Precision

- Fatigue-free operation thanks to precise and intuitive electrical steering unit
- Rounded forks are easier to thread into pallets
- Complete control: smooth, accurately controlled starting and acceleration behaviour
- Precise operation even in confined spaces thanks to compact tiller shape

Ergonomics

- Protects the back: air-cushioned stand-on platform can be adjusted to individual driver's weight
- Ergonomic and intuitive operation: driving, lifting and steering processes can be simultaneously controlled by left- or right-handed operators using just one hand
- Optional lateral battery change for even greater availability

Compactness

- High pallet reloading rate: compact size allows for quick and safe operation
- The truck's compact dimensions, articulated tiller and outstanding manoeuvrability allow work to be carried out in narrow aisles

Safety

- All-round safety: height-adjustable side guards keep the driver safe and stable, and provide optimal protection in all driving situations
- Optional combi-tiller increases the safety distance, which enables an increased maximum speed of 6 km/h in pedestrian mode
- Safe around corners: curve speed control automatically adapts speed to the steering angle when cornering
- Maximum driver protection: sensitive impact plate in the optimal position
- Accidental roll-back eliminated: automatic stop function also on ramps

Environmental Responsibility

- Low operating costs: low energy consumption and long maintenance intervals
- ECO driving programme: maximum energy efficiency at the touch of a button
- Very few noise emissions due to extremely quiet drive and lifting motor
- Over 95 percent of all materials used are recyclable

EXU-SF Low Lift Pallet Truck with Hinged Platform Equipment Variants



	EXU-SF 20	
General	Air-cushioned, individually adjustable stand-on platform for maximum operator comfort	●
	Air-cushioned stand-on platform with preset cushioning settings for high levels of operator comfort	○
	Adjustable DIN A4 writing pad	○
	Load capacity of 2 tonnes	●
	Easy-grip tiller for left- and right-handed operators	●
	Provision for STILL data terminal or scanner	○
	Two driver programmes (ECO and BOOST) for optimum efficiency or maximum performance	●
	Various fork lengths	○
	Display	○
	Cold storage version	○
	High-performance AC drive motor has very low maintenance costs	●
	Sensitive electrical steering unit minimizes operator fatigue	●
	STILL DRIVESpeed	○
	Accessories bracket	○
Tyres	Drive wheel tyres, polyurethane	●
	Drive wheel tyres, polyurethane, profiled	○
	Drive wheel tyres, solid rubber	○
	Drive wheel tyres, solid rubber, profiled	○
	Drive wheel tyres, solid rubber, natural-coloured	○
	Drive wheel tyres, solid rubber, natural-coloured, profiled	○
	Load roller tyres, polyurethane, single	○
	Load roller tyres, polyurethane, tandem	●
	Load roller tyres, polyurethane, single, lubricated axles and lifting link	○
Load roller tyres, polyurethane, tandem, lubricated axles and lifting link	○	
Safety	FleetManager: access authorisation, shock detection, reports	○
	Combi-tiller steering for high efficiency and safety levels	○
	PIN code access	○
	Foot guard	○
	Access authorisation STILL key	●
	Individual height-adjustable side guards for greater safety while working	●
Battery	Load backrest	○
	Battery compartment for 200 to 250 Ah battery, for changing batteries with a crane	●
	Battery compartment for 300 to 375 Ah battery, for changing batteries with a crane	○
	Battery compartment for 200 to 250 Ah battery, for changing batteries with a lateral battery changing system	○
	Battery compartment for 300 to 375 Ah battery, for changing batteries with a lateral battery changing system	○
	82 Ah STILL Li-Ion battery	○
	164 Ah STILL Li-Ion battery	○
	205 Ah STILL Li-Ion battery	○
410 Ah STILL Li-Ion battery	○	
Built-in charger with protection to prevent operator unintentionally driving while battery is charging	○	

● Standard ○ Optional — Not available

EXU-SF Low Lift Pallet Truck with Hinged Platform

Precision and manoeuvrability



The EXU-SF also offers maximum safety levels in pedestrian mode. The unique combi-tiller increases the safety distance, enabling operators to reach speeds of up to 6 km/h even in pedestrian mode. The tiller can be folded up for use in narrow spaces. In this case, operators are still protected against accidents as the truck speed is automatically adapted to 4 km/h.



Comfortable driving: In ride-on mode on the optimally cushioned stand-on platform, the truck can reach speeds of up to 6 km/h when the side guards are folded up.



Even greater handling performance possible. With the side guards are folded down, drivers are protected even at high speeds. This ensures even more effective material handling with driving speeds of up to 9 km/h.

EXU-SF Low Lift Pallet Truck with Hinged Platform
Precision and manoeuvrability



ECU-SF Low Lift Pallet Truck with Hinged Platform

Precision and manoeuvrability

This specification sheet to VDI Guidelines 2198 only provides technical values for the standard truck. Different tyres, other masts, additional equipment etc. may produce different figures.



Category	Item	Parameter	Unit	Value
Distinguishing marks	1.1	Manufacturer		STILL
	1.2	Manufacturer's type designation		ECU-SF
	1.3	Drive		Electric
	1.4	Operator type		Standing/pedestrian
	1.5	Capacity/load	Q	kg 2000
	1.6	Load centre distance	c	mm 600 ¹
	1.8	Load distance	x	mm 872
	1.9	Wheel base	y	mm 1304
	Weights	2.1	Service weight (incl. battery)	
2.2		Axle load, laden	drive end/load end	kg 1676/978
2.3		Axle load, unladen	drive end/load end	kg 79/575
Tyres/chassis	3.1	Tyres		Polyurethane
	3.2	Tyre size	drive end	mm $\varnothing 85 \times 90$
	3.3	Tyre size	load end	mm $\varnothing 230 \times 100$
	3.5	Number of wheels (x = driven)	drive end/load end	1x-2/2
	3.6	Tread	drive end/load end	b ₁₀ /b ₁₁ mm 398/485
	Dimensions	4.4	Lift	h ₃
4.9		Height of tiller in driving position	min./max.	h ₁₄ mm 1145/1342
4.15		Height lowered	h ₁₃	mm 85
4.19		Overall length without load	platform closed/open	l ₁ mm 1854/2180 ¹
4.20		Length to face of forks	platform closed/open	l ₂ mm 704/1030
4.21		Total width	b ₁	mm 710
4.22		Fork dimensions	s/e/l	mm 50/162/1150
4.25		Overall fork width	b ₅	mm 560
4.32		Ground clearance, centre of wheel base	m ₂	mm 33
4.33		Working aisle width with 1000 x 1200 pallet crossways	platform closed/open	A _{st3} mm 1925 ² /2604 ²
4.34		Working aisle width with 800 x 1200 pallet lengthways (b ₁₂ x l ₆)	platform closed/open	A _{st3} mm 2125/2622
4.35	Turning radius	platform closed/open	W _a mm 1597/1904	
Performance	5.1	Travel speed	laden/unladen	km/h 6/6 (7.5 ³)
	5.2	Lift speed	laden/unladen	m/s 0.034/0.045
	5.3	Lowering speed	laden/unladen	m/s 0.045/0.045
	5.7	Gradeability	laden/unladen	% 0.7 ^{1,4} /10.2 ^{1,4}
	5.8	Max. gradeability kB5	laden/unladen	% 4.7 ^{1,4} /21.3 ^{1,4}
5.10	Service brake			Electromagnetic
Electric engine	6.1	Drive motor, rating S2 = 60 min		kW 1.2
	6.2	Lift motor, rating at S3		kW 1.2
	6.3	Battery according to DIN 43531/35/36; A, B, C, no		DIN 43535 B
	6.4	Battery voltage/nominal capacity K ₅	V/Ah	24/250
	6.5	Battery weight ±5% (depends on make)	kg	220
	6.6	Energy consumption according to VDI cycle	kWh/h	1.06
Other	8.1	Drive control		Pulse control
	8.4	Sound level at driver's ear		dB(A) <70

¹ for fork $l = 1150$ mm, $b_5 = 560$ mm

² for fork length $l = 980$ mm

³ when platform is unfolded and guard is open

⁴ when platform is unfolded

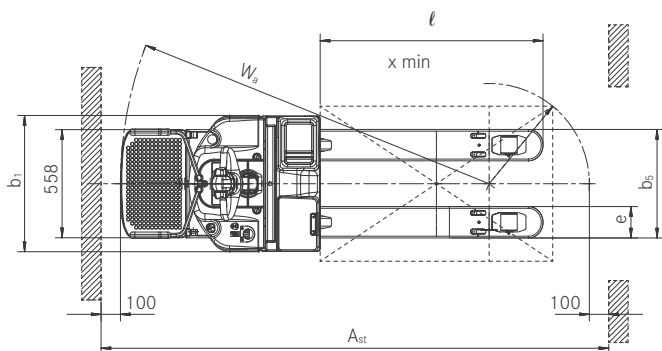

Top view

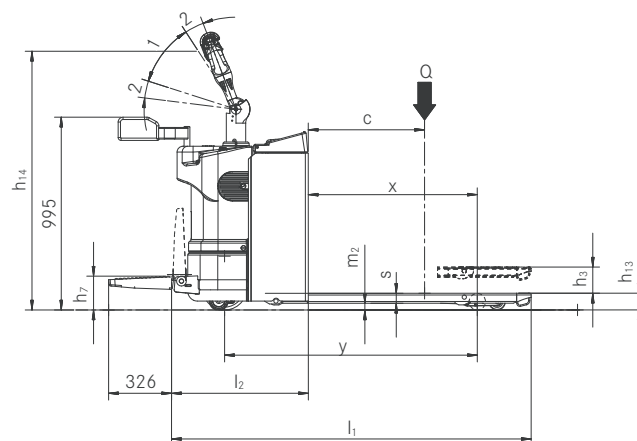

Side view

ECU-SF Low Lift Pallet Truck with Hinged Platform Turning Radius

Turning radius W_a for determining the working aisle width

Fork length l		Load centre c in mm	Distance x in mm	Wheel base y in mm	Turning radius W_a in mm		Overall length l_1 in mm	
					Platform folded	Platform unfolded	Platform folded	Platform unfolded
800	mm	400	522	952	1247	1554	1504	1830
980	mm	500	702	1132	1427	1734	1684	2010
1150	mm	600	872	1302	1597	1904	1854	2180
1450	mm	715	1172	1602	1897	2204	2154	2480
1600	mm	800	1322	1752	2047	2354	2304	2630

¹ Fork lifted

Detailed Photos



Outstanding flexibility for every job: Thanks to its hinged, stand-on platform and side guards, the truck can be adapted to all warehouse conditions, including very narrow warehouses, aisles with requisite speed restrictions and jobs over long distances



Always available: Sufficient energy for extended use and possibility of changing the battery



All-round safety: Optional side guards can be easily and quickly lowered, keeping drivers safe and stable, and providing optimal protection in all driving situations



Ergonomic and intuitive operation: driving, lifting and steering processes can be controlled single-handedly by either left- or right-handed operators



Effective material handling: Up to 2,000 kg lifting capacity and maximum speed of 7.5 km/h

ECU-SF Low Lift Pallet Truck with Hinged Platform

Precision and manoeuvrability

Fast and safe: optional side guards can be opened and closed using just one hand

Perfect ergonomics: stand-on platform is just 170 mm high, allowing operators to easily mount and dismount

High pallet reloading rate: compact size allows for quick and safe operation

The powerful ECU-SF low lift pallet truck from STILL features a hinged platform and a load capacity of 2,000 kg, making it the ideal choice for loading and unloading lorries and for transporting goods horizontally. This compact warehouse helper can be manoeuvred accurately and safely in narrow spaces. Its rounded forks can be easily threaded into pallets. This low-maintenance truck gets the job done reliably, from lightweight jobs over multiple shifts in the industrial sector to handling material in retail environments.

The chassis is covered with shock-resistant plastic, providing the robust truck with outstanding protection in harsh environments. The platform on the ECU-SF is very low at just 170 mm. This enables operators to quickly and safely get on and off the stand-on platform. The precise and intuitive electrical steering unit minimizes operator fatigue and enables goods to be turned around fast. Optional side guards keep the driver safe and stable, and provide optimal protection in all driving situations. These can be opened and closed using just one hand.



Extensive Equipment

Power

- Effective material handling: up to 2,000 kg lifting capacity and maximum speed of 7.5 km/h
- Powerful, reliable and low-maintenance drive motor
- Outstanding reliability: robust outer panels can withstand forceful impacts.
- Sufficient energy for extended use: high battery capacity with 24-volt technology
- Maximum speeds for different situations: 6 km/h in pedestrian mode and 7.5 km/h in ride-on mode when side guards are folded down

Precision

- Fatigue-free operation thanks to precise and intuitive electrical steering unit
- Rounded forks are easier to thread into pallets
- Complete control: smooth, accurately controlled starting and acceleration behaviour
- Precise operation even in the most confined spaces thanks to compact shape

Ergonomics

- Ergonomic and intuitive operation: driving, lifting and steering processes can be simultaneously controlled by left- or right-handed operators using just one hand
- The ECU-SF can be accurately steered in all conditions thanks to the ergonomic layout of control elements
- Easy to board: the platform is just 170 mm high and can be boarded very easily and effortlessly
- Relaxed working conditions: perfectly cushioned stand-on platform ensures comfortable working conditions
- The side guards can be simultaneously opened and closed using only one hand

Compactness

- High pallet reloading rate: compact size allows for quick and safe operation
- The truck's compact dimensions, hinged stand-on platform and outstanding manoeuvrability allow work to be carried out in very narrow aisles
- Working in confined spaces: flowing lines and compact dimensions enable work to be carried out in HGVs
- The battery is protected from damage even in confined spaces: the battery compartment is made from a continuous plate to protect against impacts

Safety

- Optional side guards keep the driver safe and stable, and provide optimal protection in all driving situations
- Maximum driver protection: sensitive impact plate in the optimal position
- Accidental roll-back eliminated: automatic stop function also on ramps
- Non-slip mat on the stand-on platform keep drivers in a stable position

Environmental Responsibility

- Energy efficient due to energy recovery when braking
- Very few noise emissions due to extremely quiet drive and lifting motor
- Over 95 percent of all materials used are recyclable

ECU-SF Low Lift Pallet Truck with Hinged Platform Equipment Variants



		ECU-SF
General	Ergonomics adapted for maximum comfort and safety	●
	Cushioned, hinged stand-on platform for outstanding user comfort	●
	Large writing pad with document clamp	●
	Load capacity of 2 tonnes	●
	Easy-grip tiller for left- and right-handed operators	●
	Various fork lengths	○
	Cold storage version	○
	The intuitive electrical steering unit reduces operator fatigue to a minimum	●
Tyres	Drive wheel tyres, polyurethane	●
	Drive wheel tyres, solid rubber	○
	Extendible wheels of solid rubber for lateral pallet lifting	○
	Load roller tyres, polyurethane, single	●
	Load roller tyres, polyurethane, tandem	○
Safety	Hinged side guards increase speed to 7.5 km/h	○
Battery	Built-in charger	○
	Battery compartment for battery up to 250 Ah, for changing batteries with a crane	●
	Battery compartment for battery up to 300 Ah, for changing batteries with a crane	○

● Standard ○ Optional — Not available

STILL



STILL Materials Handling Ltd
Aston Way
Leyland Preston
PR26 7UX
Tel.: +44 (0)845 603 6827

STILL Materials Handling Ltd
Jacks Way
Hill Barton
Business Park
Clyst St. Mary
Exeter
EX5 1FG
Tel.: +44 (0)345 603 6827
info@still.co.uk

For further information please visit:

www.still.co.uk

STILL is certified in the following areas: Quality management, occupational safety, environmental protection and energy management.



first in intralogistics