

STILL



RX 60 Technical Data Electric Forklift Truck

RX 60-60

RX 60-70

RX 60-80

RX 60-80/900



IFOY AWARD
international forklift truck
of the year 2015

first in intralogistics

RX 60-60/80 Electric Forklift Truck

Making light work of things

This specification sheet, which conforms to VDI guideline 2198, provides the technical values for the standard equipment only.
Different tyres, other masts, the use of accessories, etc., may result in other values.



			STILL	STILL	STILL	STILL		
			RX 60-60	RX 60-70	RX 60-80	RX 60-80/900		
Distinguishing marks	1.1	Manufacturer						
	1.2	Manufacturer's type designation						
	1.2.1	Manufacturer model number						
	1.3	Drive		Electric	Electric	Electric		
	1.4	Operator type		Seated	Seated	Seated		
	1.5	Rated capacity/rated load	Q	kg	6000	7000	8000	
	1.6	Load centre distance	c	mm	600	600	600	
	1.8	Load distance, centre of drive axle to fork	x	mm	710	720	720	
	1.9	Wheel base	y	mm	2285	2285	2285	
Weights	2.1	Empty weight (incl. battery)		kg	12032	12414	13282	
	2.2	Axle loading, laden	front/rear	kg	15860/2172	17702/1712	19311/1971	
	2.3	Axle loading, unladen	front/rear	kg	6413/5619	6591/5823	6627/6655	
Tyres/chassis	3.1	Tyres		Superelastic	Superelastic	Superelastic	Superelastic	
	3.2	Tyre size	front	mm	355/50-20	8.25-15	315/70-15	
	3.3	Tyre size	rear	mm	250-15	250-15	250-15	
	3.5	Wheels, number (x = driven)	front/rear		2x/2	4x/2	4x/2	
	3.6	Tread	front/rear	b ₁₀ /b ₁₁	mm	1364/1358	1510/1358	1561/1358
	Basic dimensions	4.1	Angle of mast/fork carriage	forward/backward	α/β	°	5/8	5/8
4.2		Height of mast when retracted		h ₁	mm	2710	2710	
4.3		Free lift		h ₂	mm	150	150	
4.4		Lift ¹		h ₃	mm	3550	3150	
4.5		Height of mast when extended		h ₄	mm	4440	4240	
4.7		Height above protected roof (cab)		h ₆	mm	2697	2697	
4.8		Seat height in terms of SIP		h ₇	mm	1719	1719	
4.12		Clutch height		h ₁₀	mm	520/670	520/670	
4.19		Total length		l ₁	mm	4640	4660	
4.20		Length including fork backs		l ₂	mm	3450	3460	
4.21		Overall width		b ₁	mm	1679	1996	
4.22		Fork dimensions		s/e/l	mm	70/150/1200	70/150/1200	
4.23		Fork carriage ISO 2328, class/type A, B				ISO IV A	ISO IV A	
4.24		Fork carriage width		b ₃	mm	1600	1800	
4.31		Ground clearance under mast		m ₁	mm	220	220	
4.32		Ground clearance, centre wheel base		m ₂	mm	210	210	
4.34.1		Working aisle width with pallet 1000 x 1200 crossways		A _{st}	mm	4917	4927	
4.34.2		Working aisle width with pallet 800 x 1200 lengthways		A _{st}	mm	5117	5127	
4.35		Turning radius		W _a	mm	3007	3007	
4.36		Smallest pivoting distance		b ₁₃	mm	877	877	
Performance data	5.1	Driving speed ⁵	laden/unladen	km/h	14/17 // 18/20 ⁴	14/17 // 18/20 ⁴	14/17 // 18/20 ⁴	
	5.2	Lifting speed ⁵	laden/unladen	m/s	0.31/0.37 // 0.41/0.48 ⁴	0.30/0.37 // 0.38/0.48 ⁴	0.28/0.37 // 0.36/0.48 ⁴	
	5.3	Lowering speed ⁵	laden/unladen	m/s	0.56/0.52	0.53/0.42	0.53/0.42	
	5.5	Traction	laden/unladen	N	28788/29023	28674/28936	28468/28767	
	5.6	Max. traction	laden/unladen	N	44000	44000	44000	
	5.7	Gradeability	laden/unladen	%	16.3/25.0	16.1/24.1	16.0/23.0	
	5.8	Max. gradeability	laden/unladen	%	19.0/29.0	18.0/27.0	16.0/25.0	
	5.9	Acceleration time (15 m) ⁵	laden/unladen	s	7.3/6.2 // 6.3/5.8 ⁴	7.5/6.5 // 6.4/5.9 ⁴	7.7/6.6 // 6.7/5.9 ⁴	
	5.10	Service brake			Mechanic/hydraulic	Mechanic/hydraulic	Mechanic/hydraulic	
	Electric engine	6.1	Drive motor, output with S3 = 60 min		kW	2 x 10.5	2 x 10.5	2 x 10.5
6.2		Lifting motor, output at 15% ED		kW	2 x 21.0	2 x 21.0	2 x 21.0	
6.3		Battery in accordance with DIN 43531/35/36 A, B, C, no			DIN 43536 A	DIN 43536 A	DIN 43536 A	
6.4		Battery voltage	U	V	80	80	80	
6.4.1		Battery capacity K _s		Ah	1120 (-1240) // 1085 ⁴	1120 (-1240) // 1085 ⁴	1120 (-1240) // 1085 ⁴	
6.5		Battery weight		kg	2824	2824	2824	
6.6		Energy consumption, 45 VDI combustion cycles/hour		kWh/h	12.6	14.5	16.0	
6.7		Handling capacity ⁵		t/h	354 // 358 ⁴	412 // 434 ⁴	462 // 492 ⁴	
Miscellaneous	6.8	Energy consumption at handling capacity		kWh/h	15.4 // 20.4 ⁴	16.1 // 20.6 ⁴	16.5 // 20.9 ⁴	
	10.1	Working pressure for accessory equipment		bar	250	250	250	
	10.2	Oil volume for accessory equipment		l/min	60	60	60	
	10.7	Sound pressure level L _{PA2} (operator's position) ²		dB(A)	<70	<70	<70	
	Human vibrations: acceleration in accordance with EN 13059		m/s ²	<0.7	<0.7	<0.7		
10.8	Trailer coupling, item/DIN type		Bolt	Bolt	Bolt	Bolt		

¹ The nominal lift stated includes the tyre deflection and tyre diameter tolerances

² Excluding cab. Different values with cab

³ Fork arm overhang not considered

⁴ Option with air-cooled PowerPlusLife battery

⁵ Values apply to standard version and permanent sprint mode (no performance restrictions for temperature balancing)

RX 60-60/80 Electric Forklift Truck
 Technical Drawings

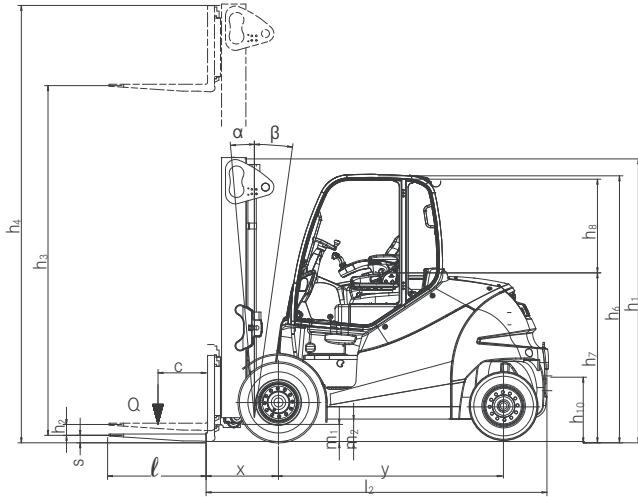

Side view

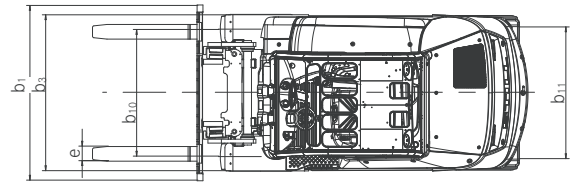

Top view

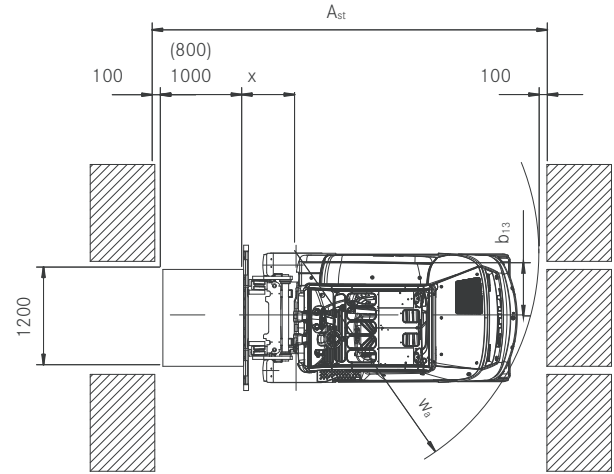

Mast Tables

				Telescopic mast		Triplex mast	
RX 60-60	Overall height	h ₁	mm	2710-4360		2710-3760	
	Free lift	h ₂	mm	110		1755-3005	
	Nominal lift	h ₃	mm	3550-6850		4770-8670	
	Maximum height	h ₄	mm	4440-7740		5660-9560	
	Maximum width	b ₁	mm	1679			
	Adjustable fork spread			mm	267/470/673/978/1181/1486 (fork carriage width 1600 mm)/1570 (fork carriage width 1800 mm)/1791 (fork carriage width 2180/2400 mm)/1866 (fork carriage width 2180 mm)/1950/2096 (fork carriage width 2400 mm)		
	Superelastic tyres	front/rear			SE 355/50-20 / SE 250-15		
	Track	front/rear	b ₁₀ /b ₁₁	mm	1364/1358		
RX 60-70	Overall height	h ₁	mm	2710-4360		2710-3960	
	Free lift	h ₂	mm	110		1555-2805	
	Nominal lift	h ₃	mm	3150-6450		4705-8455	
	Maximum height	h ₄	mm	4240-7540		5795-9545	
	Maximum width	b ₁	mm	2003			
	Adjustable fork spread			mm	267/470/673/978/1181/1486 (fork carriage width 1600 mm)/1570 (fork carriage width 1800 mm)/1791 (fork carriage width 2180/2400 mm)/1866 (fork carriage width 2180 mm)/1950/2096 (fork carriage width 2400 mm)		
	Superelastic tyres	front/rear			SE twin 8.25-15 / SE 250-15		
	Track	front/rear	b ₁₀ /b ₁₁	mm	1510/1358		
RX 60-80	Overall height	h ₁	mm	2710-4360		2710-3960	
	Free lift	h ₂	mm	110		1555-2805	
	Nominal lift	h ₃	mm	3150-6450		4705-8455	
	Maximum height	h ₄	mm	4240-7540		5795-9545	
	Maximum width	b ₁	mm	2140			
	Adjustable fork spread			mm	267/470/673/978/1181/1486 (fork carriage width 1600 mm)/1570 (fork carriage width 1800 mm)/1791 (fork carriage width 2180/2400 mm)/1866 (fork carriage width 2180 mm)/1950/2096 (fork carriage width 2400 mm)		
	Superelastic tyres	front/rear			SE twin 315/70-15 / SE 250-15		
	Track	front/rear	b ₁₀ /b ₁₁	mm	1561/1358		
RX 60-80/900	Overall height	h ₁	mm	2710-4360		2710-3960	
	Free lift	h ₂	mm	110		1320-2570	
	Nominal lift	h ₃	mm	2750-6050		3955-7705	
	Maximum height	h ₄	mm	4140-7440		5595-9345	
	Maximum width	b ₁	mm	2140			
	Adjustable fork spread			mm	267/470/673/978/1181/1486 (fork carriage width 1600 mm)/1570 (fork carriage width 1800 mm)/1791 (fork carriage width 2180/2400 mm)/1866 (fork carriage width 2180 mm)/1950/2096 (fork carriage width 2400 mm)		
	Superelastic tyres	front/rear			SE twin 315/70-15 / SE 28 x 12.5-15		
	Track	front/rear	b ₁₀ /b ₁₁	mm	1561/1432		

RX 60-60/80 Electric Forklift Truck

Basic Load Capacities

RX 60-60 Telescopic mast

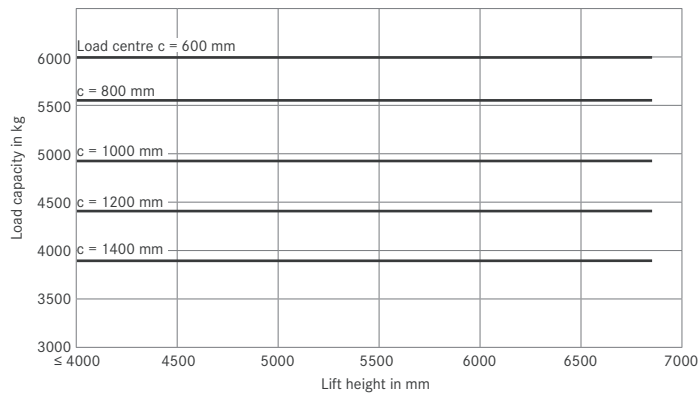

RX 60-60 Triplex mast

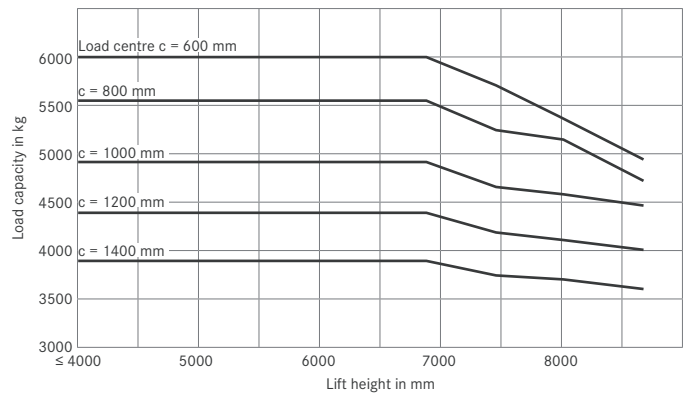

RX 60-70 Telescopic mast

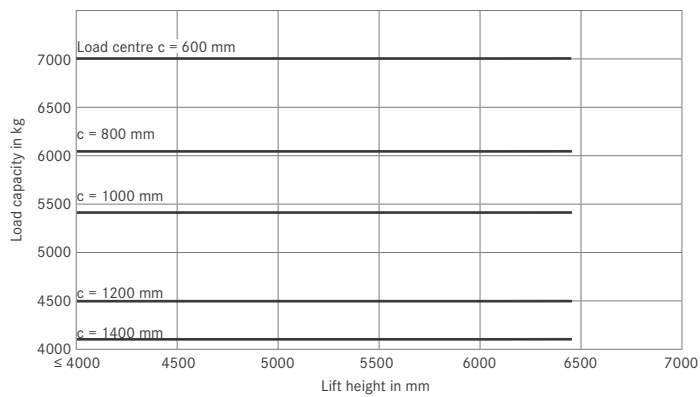

RX 60-70 Triplex mast

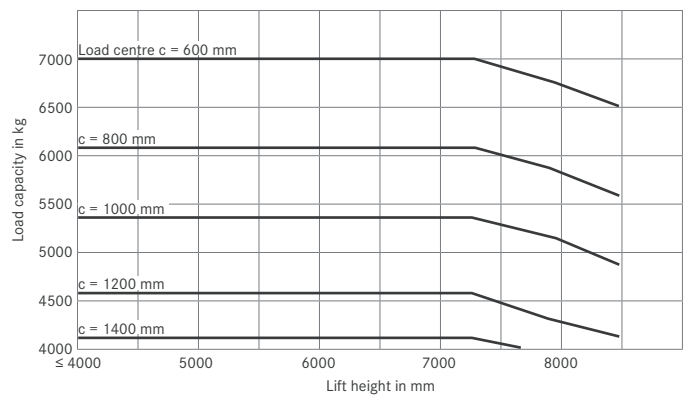

RX 60-80 Telescopic mast

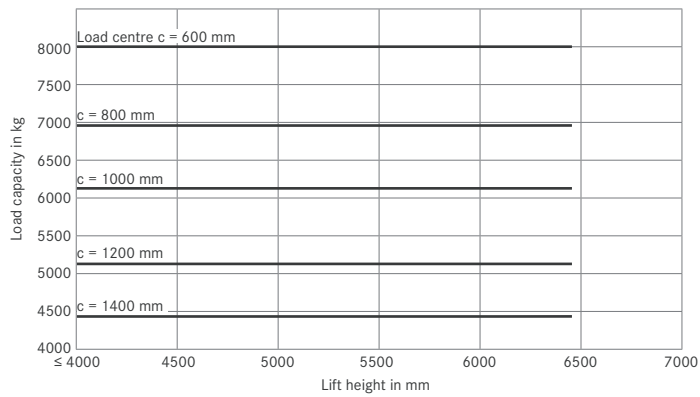

RX 60-80 Triplex mast

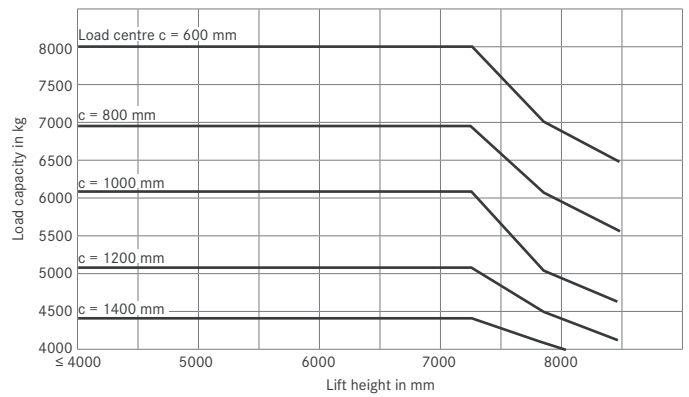

RX 60-80/900 Telescopic mast

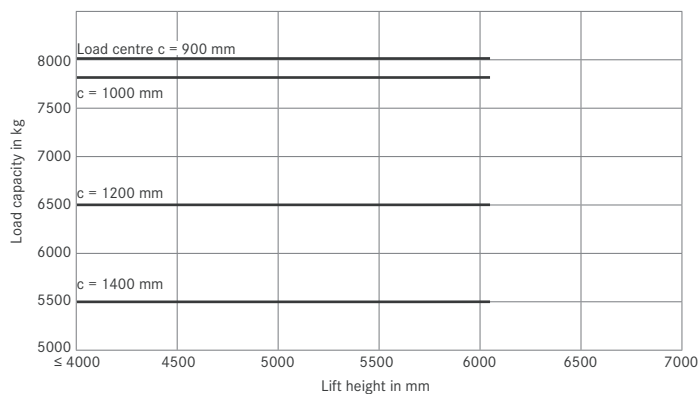

RX 60-80/900 Triplex mast

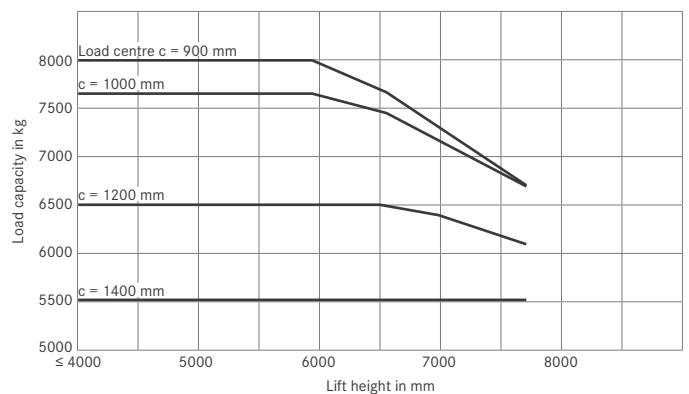

RX 60-60/80 Electric Forklift Truck
Detailed Photos



Easy handling of heavy loads in tight spaces



Flexible indoor and outdoor use



Non-slip steps visible from the top for safe access and exit



Manoeuvrable and stable high pendulum axle



Fast battery change with ECU 30 high lift truck



High availability thanks to fast battery changeover



Easily accessible maintenance positions



PowerPlusLife battery with particularly long service life

RX 60-60/80 Electric Forklift Truck

Making light work of things

Compact design and excellent mobility

The powerful electrical drive unit has very low environmental impact and a high handling rate

Excellent visibility due to driver's cab being set to one side and high seat position

Optional sprint mode and cooled PowerPlusLife battery for top driving speed of 20 km/h



The electric forklifts in the RX 60-60/80 series are emission-free powerhouses. They have particularly high performance, as well as being extremely compact and manoeuvrable. The flagship model, the RX 60-80/900, can lift up to eight tonnes in working aisle widths of just 4,999 mm at a load centre of 900 mm. These strong forklifts are emission-free both inside and out, as well as being a highly efficient means of transport – even in damp and dusty environments. The sensitive control and the maximum speed of up to 17 km/h ensure

a high handling rate. Besides the sensitive controls the maximum driving speed of up to 17 km/h in the standard version and 20 km/h in the optional sprint mode and with the PowerPlusLife battery ensures high turnover performance.

Whether for freight carriers or manufacturing sectors, handling heavy loads or fast loading and unloading of lorries, its high performance, precise hydraulics and well-conceived forklift ergonomics make the strongest RX-60 model an unbeatable warehouse assistant.

Extensive Equipment

Power

- Nominal load capacity of up to eight tonnes at a load centre of 900 mm
- Maintenance-free 80 V three-phase drive
- Effective goods materials handling due to high driving speed of up to 17 km/h or 20 km/h with the optional, air-cooled PowerPlusLife battery
- Sufficient energy for multi-shift operations due to battery capacity of 1,240 Ah and lateral battery replacement
- Air-cooled battery with especially long service life

Precision

- Optimum set-up of drive unit and hydraulic control at maximum handling rate or maximum efficiency
- Speed, acceleration and braking can be individually set
- Sensitive operation and continuous control of lifting speed thanks to the latest proportional valve technology
- Driver's cab set to one side gives optimum view of loads to enable precise load handling
- Intuitive single-pedal control

Ergonomics

- The roomy, comfortable driver's cab can be individually set up
- Hydraulic power steering with small steering wheel, optimally offset to the left
- Narrow, adjustable steering column with no annoying display instruments
- Central display and control unit in the driver's field of vision
- Generous storage space in the right and rear workstation areas
- Consistent operating concept across the whole RX series

- Individually adjustable control concepts (mini-lever, fingertip or joystick)
- Simple and safe entry and exit

Compactness

- Compact forklift sizes and excellent mobility enable working aisle widths of under five metres
- Narrow vehicle frames enable efficient block forklifting

Safety

- Perfect all-round visibility due to higher driver's seat, driver's cab being set to one side, large viewing window in roof and C-pillar at the rear
- Optimum safety levels thanks to the forklift's low centre of gravity and steering axle with high self-aligning bearing
- Electrically heated rear windscreen ensures clear visibility in cold environments
- The forklift's low centre of gravity and a pendulum pivot steering axle ensure optimum visibility
- Outstanding forklift stability when cornering, no electronic assistance required
- Wear-free disc brakes that run in an oil bath

Environmental Responsibility

- Low operating costs due to low energy consumption in all operating cycles and long maintenance intervals
- Blue-Q efficiency model saves up to ten per cent energy at the press of a button with no loss of performance
- Over 95 per cent of all installed materials are recyclable

RX 60-60/80 Electric Forklift Truck

Equipment Variants



	RX 60-60	RX 60-70	RX 60-80	RX 60-80/900
	●	●	●	●
Low operating costs due to low energy consumption in all operating cycles and long maintenance intervals	●	●	●	●
Steel protected roof	●	●	●	●
Weather-protected, canvas or full cab	○	○	○	○
Tinted front windscreen, rear and front windows, windscreen washing/wiping system	○	○	○	○
Single-pedal control	●	●	●	●
Dual-pedal control	○	○	○	○
Integrated holders and drink holder	●	●	●	●
Display and function buttons protected from water spray	●	●	●	●
Pad with clipboard (removable)	○	○	○	○
Grammer MSG 65 leatherette cover	●	●	●	●
Textile cover, airsprung, leatherette cover, lumbar support, height-adjustable back extension, heated seat	○	○	○	○
Handle on protected roof bar, back right	●	●	●	●
Horizontal spring plate for driver's seat to minimise human vibrations	○	○	○	○
Document pocket on the seat back	○	○	○	○
Roof liner with interior lighting	○	○	○	○
Radio/MP3 player with USB connection	○	○	○	○
Protective sunshade and sunblind	○	○	○	○
1500 W electrical heating incl. defrosting blaster	○	○	○	○
Cold storage version, display and hydraulic oil can be used at up to -30 °C	○	○	○	○
Telescopic clear view mast	○	○	○	○
Triple clear view mast	○	○	○	○
Load protection grid	○	○	○	○
Mast vertical position	○	○	○	○
Hydraulic accumulator in the lifting cylinder to attenuate pressure peaks in the hydraulic system	○	○	○	○
Angle of incline five/eight degrees, front/rear incline	●	●	●	●
Bellows protects the tilt cylinder from dust and moisture	○	○	○	○
Superelastic single tyres, SIT system	●	—	—	—
Superelastic twin tyres, SIT system	○	●	●	●
Noise-optimised hydraulic pump	●	●	●	●
Proportional valve technology for especially sensitive movements	●	●	●	●
Individual parametrisation options for hydraulic functions	●	●	●	●
Mini-lever with armrest, two levers	●	●	●	●
Mini-lever with armrest, three or four levers, fingertip or joystick	○	○	○	○
Increased lift speed in powerful sprint mode	○	○	○	○
Five driving programs	●	●	●	●
Faster acceleration and driving speed of up to 20 km/h in the powerful sprint mode	○	○	○	○
Blue-Q energy-saving program	●	●	●	●
Smooth, continuous acceleration and reversing	●	●	●	●
Maintenance-free drives for driving, steering and lifting	●	●	●	●
Enclosed components to protect against dust and damp	●	●	●	●
Operating hours counter only operational with drive and lifting motor	●	●	●	●
Wear-free disc brakes that run in an oil bath	●	●	●	●
Energy recovery when braking	●	●	●	●
Hydraulic parking brake	●	●	●	●
Forklift has low centre of gravity and steering with high self-aligning bearing for optimum levels of safety	●	●	●	●
Protective grille roof	○	○	○	○
EasyBelt restraint system for quick and safe fastening and unfastening	○	○	○	○
Easily accessible maintenance positions	●	●	●	●
IWS restraint system with left-located strap opening	○	○	○	○
Headlights and LED lighting performance	○	○	○	○
Speed limiter adjustable by driver	○	○	○	○
STILL Safety Light warning device, illuminated blue	○	○	○	○
ATC (Assistance Truck Control) system for safe exit/parking and seat belt control	○	○	○	○
Load measuring with ±2% precision	○	○	○	○
FleetManager: access authorisation, shock detection, reports	○	○	○	○

● Standard ○ Optional — Not available

STILL



STILL Materials Handling Ltd
Aston Way
Leyland Preston
PR26 7UX
Tel.: +44 (0)845 603 6827

STILL Materials Handling Ltd
Jacks Way
Hill Barton
Business Park
Clyst St. Mary
Exeter
EX5 1FG
Tel.: +44 (0)345 603 6827

info@still.co.uk

For further information please visit:

www.still.co.uk



STILL is certified in the following areas: Quality management, occupational safety, environmental protection and energy management.



first in intralogistics